



Operation Manual for Torque Sensor

Type DR-2800





Imprint

Manufacturer, Place	Lorenz Messtechnik GmbH, D-73553 Alfdorf.
Valid for...	Torque sensor type DR-2554
Copyright	© 2012 Lorenz Messtechnik GmbH, Alfdorf.
Interdiction of Reprint	Reprint in whole or in part with written permission, only.
Change Notice	Technical changes are reserved.



References in this Text

1.6 Warning Notes; Page 6



Attention must be paid to the accident prevention regulations of the trade associations. Coverings and casings are necessary before operating the sensor. This is also valid for commissioning, maintenance and trouble shooting.

Duties of the coverings and casings are:

- ⇒ Protection from detaching parts
- ⇒ Protection from contusion and shear
- ⇒ Prevention from reaching rotating parts
- ⇒ Prevention from being tangled up and/or getting caught by parts

Coverings may

- ⇒ Not grind
- ⇒ Not rotate

Coverings are also necessary outside of operating and motion travel areas of persons. These demands can be modified if other sufficient safety devices are available. During operation, the safety precautions must be operative. Vibrations can cause device damages.

4 Mechanical Assembly; Page 8



Caution: Inadmissibly large forces may not act on the sensor or the couplings during the assembly. Connect the sensor electrically during the assembly and observe the signal, the measurement signal may not exceed the limit values



To avoid falling down, the sensor must be supported during the assembly.



Admissible assembly offset from rotor to stator: **4.2 Stator Assembly**



Caution! At alternating torque, the screws for the flange connections must absolutely be secured with screw locks.

4.4.1 Alignment of the Measurement Arrangement; Page 11



For details see the manual of the couplings and data sheet of the torque sensor for the limit thrust load and the limit shear force.

6.1 Engaging; Page 12



The warm-up period of the torque sensor is approx. 5 minutes.

6.4.2 Torsional Natural Resonances; Page 12

Operation of the device in natural resonance can lead to permanent damages.

6.4.3 Bending Natural Resonances; Page 13



Operation of the device in bending natural resonance can lead to permanent damages.



Contents

1	Read First.....	5
1.1	Safety and Caution Symbols.....	5
1.2	Intended Use.....	5
1.3	Dangers.....	5
1.3.1	Neglecting of Safety Notes.....	5
1.3.2	Residual Dangers.....	5
1.4	Reconstructions and Modifications.....	5
1.5	Personnel.....	5
1.6	Warning Notes.....	6
2	Term Definitions.....	6
2.1	Terms.....	6
2.2	Definition of the Pictograms on the Torque Sensor.....	6
3	Product Description.....	6
3.1	Mechanical Setup.....	7
3.2	Electrical Setup.....	7
4	Mechanical Assembly.....	8
4.1	Rotor Assembly.....	8
4.2	Stator Assembly.....	9
4.3	Basic Assembly.....	9
4.3.1	Assembly Example.....	9
4.3.2	Using Center Bore.....	10
4.4	Couplings.....	10
4.4.1	Alignment of the Measurement Arrangement.....	11
5	Electrical Connection.....	11
5.1	Pin Connection.....	11
5.2	Cable.....	11
5.3	Shielding Connection.....	11
5.4	Installation of Measuring Cables.....	11
5.5	Speed Sensor (Option).....	12
6	Measuring.....	12
6.1	Engaging.....	12
6.2	Direction of Torque.....	12
6.3	Static / Quasi-Static Torques.....	12
6.4	Dynamic Torques.....	12
6.4.1	General.....	12
6.4.2	Torsional Natural Resonances.....	12
6.4.3	Bending Natural Resonances.....	13
6.5	Speed Limits.....	13
6.5.1	Balancing.....	13
6.6	Disturbance Variables.....	13
7	Maintenance.....	13
7.1	Rotating Sensors.....	13
7.2	Trouble Shooting.....	14
8	Transportation and Storage.....	14
8.1	Transportation.....	14
8.2	Storage.....	14
9	Disposal.....	15
10	Calibration.....	15
10.1	Proprietary Calibration.....	15
10.2	DKD-Calibration.....	15
10.3	Re-Calibration.....	15
11	Data Sheet.....	15
12	Literature.....	15



1 Read First

1.1 Safety and Caution Symbols

**Caution:**

Injury risk for persons
Damage of the device is possible.

**Note:**

Important points to be considered.

1.2 Intended Use

Lorenz Messtechnik GmbH devices may only be used for measurement tasks and the directly related control tasks. Any other use is considered improper. The torque sensors are not safety components in the sense of the intended use. The sensors need to be transported and stored appropriately. The assembly, commissioning and disassembling must take place professionally.

1.3 Dangers

The torque sensor is fail-safe and corresponds to the state of technology.

1.3.1 Neglecting of Safety Notes

At inappropriate use, residual dangers can emerge (e.g. by untrained personnel). The operation manual must be read and understood by each person entrusted with the assembly, maintenance, repair, operation and disassembly of the torque sensor.

1.3.2 Residual Dangers

The plant designer, the supplier, as well as the operator must plan, realize and take responsibility for safety-related interests for the sensor. Residual dangers must be minimized. Residual dangers of the torque measurement technique must be pointed out.

Human mistakes must be considered. The construction of the plant must be suitable for the avoidance of dangers. A danger-analysis for the plant must be carried out.

1.4 Reconstructions and Modifications

Each modification of the sensors without our written approval excludes liability on our part.

1.5 Personnel

The installation, assembly, commissioning, operation and the disassembly must be carried out by qualified personnel only. The personnel must have the knowledge and make use of the legal regulations and safety instructions.



1.6 Warning Notes



Attention must be paid to the accident prevention regulations of the trade associations. Coverings and casings are necessary before operating the sensor. This is also valid for commissioning, maintenance and trouble shooting.

Duties of the coverings and casings are:

- ⇒ Protection from detaching parts
- ⇒ Protection from contusion and shear
- ⇒ Prevention from reaching rotating parts
- ⇒ Prevention from being tangled up and/or getting caught by parts

Coverings may

- ⇒ Not grind
- ⇒ Not rotate

Coverings are also necessary outside of operating and motion travel areas of persons. These demands can be modified if other sufficient safety devices are available. During operation, the safety precautions must be operative. Vibrations can cause device damages.

2 Term Definitions

2.1 Terms

Measuring Side:

Mechanical connection of the torque sensor in which the torque to be measured is applied. Usually, this side has the smallest moment of inertia.

Drive Side:

Mechanical connection of the torque sensor on the opposite side of the measuring side, usually with the largest moment of inertia.

Low Torque Resistance Side:

The shaft of the arrangement (drive, load) which can be rotated significantly smaller with torque than the nominal torque of the torque sensor $M \ll M_{\text{nenn}}$.

2.2 Definition of the Pictograms on the Torque Sensor

The measuring side of the torque sensor is identified as follows.

Measuring side:

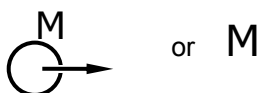

Further indications can be found on the sensor data sheet.

3 Product Description

The sensor measures static and dynamic torques. The mounting position of the torque sensor is horizontally.

Caution: it must be differentiated between measuring side and drive side, see data sheet of the sensor:

<http://www.lorenz-sensors.com>



3.1 Mechanical Setup

The sensor consists of a stationary part, the stator and a rotary part, the rotor.

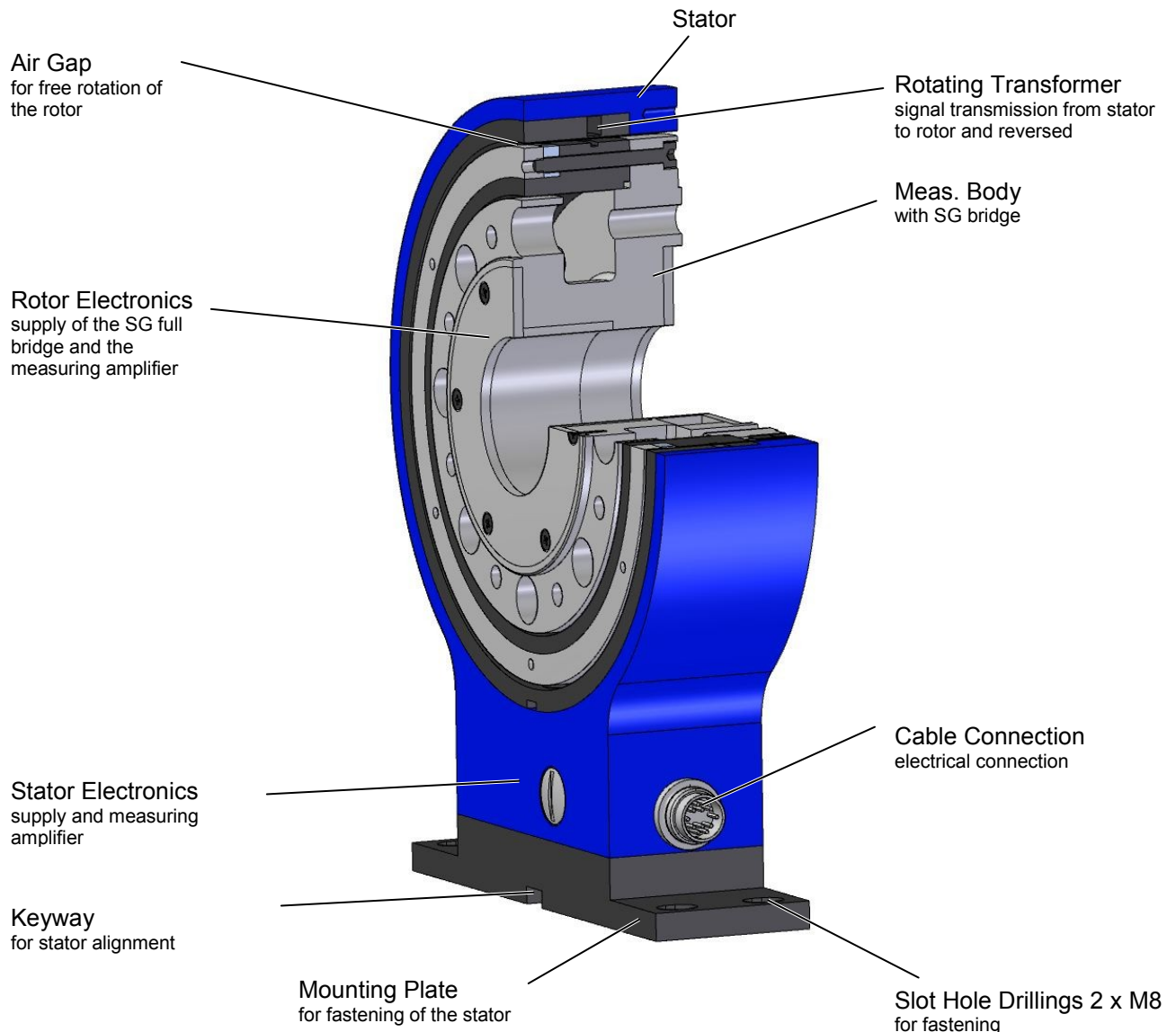

3.2 Electrical Setup

The electronics integrated in the sensor consists of two parts.

The first part is in the stator and has following tasks:

- Stabilization of the supply voltage
- Electric supply of the rotor electronics through the rotating transformer
- Preparation of the measurement signal from the rotor
- Transmission of the torque measurement signal to the cable connection

The second part of the electronics is placed in the rotor of the torque sensor with following functions:

- Supply of the SG full bridge with DC voltage
- Preparation of the electrical torque measurement signal
- Transmission of the measurement signal to the stator



4 Mechanical Assembly

4.1 Rotor Assembly



Caution: During the assembly inadmissibly large forces may not act on the sensor or the couplings. Connect the sensor electrically during the assembly and observe the signal, the measurement signal may not exceed the limit values.



To avoid falling down, the sensor must be supported during the assembly.



Admissible assembly offset from rotor to stator: **4.2 Stator Assembly**

The sensor is installed into the shaft string through flanges. Prior to the assembly, flanges must be cleaned with solvent (e.g. acetone), they must be free of foreign particles. The surface of the flange must have an evenness of minimum 0,02 mm.

For transportation and easier assembly, the torque sensor is delivered with fixing plates.

The optimal **axial position of Stator to Rotor** is defined by fixing plates.
(per plate 3 screws M4x10)

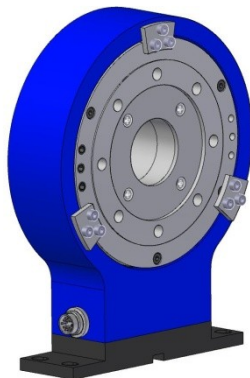
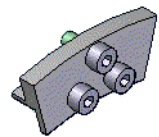

Mounted Fixing Plates

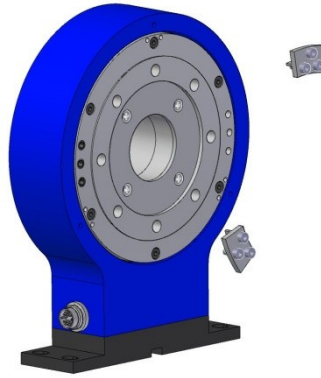

Removed Fixing Plates

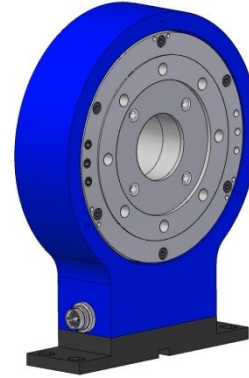

Without Fixing Plates

Tighten screws evenly on the flanges. Torque transmission by surface pressure, only. The installation and alignment of the torque sensor occurs with mounted fixing plates.

Use appropriate tightening torques for the screws of **strength 10.9** with suitable length. The screws should be secured with screw locks (e.g. LOCTITE No. 242).

Nominal Torque	Screw	Quantity	Thread depth	Tightening torque
50 / 100 N·m	M 6	8	12 mm	14 N·m
200 N·m	M 8	8	12 mm	35 N·m
500 / 1000 N·m	M12	8	12 mm	120 N·m



Caution!

At alternating torque, the flange connection screws must absolutely be secured with screw locks. Otherwise the connection screws may loosen.

The used screws may not be too long:

- Shunt of the torque measurement
- Flange connection is not twist-protected

Then remove the 3 fixing plates and control the position of shaft to stator:

- a) Axial alignment of the shaft
- b) Evenness of the air gap (shaft may not grind at the stator)



4.2 Stator Assembly

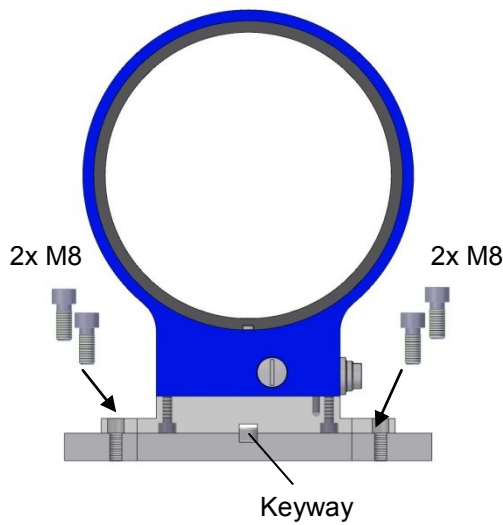

Use keyway for the axial alignment

Align stator to shaft

Rotor may not touch the stator

Note the axial position of rotor to stator
Tolerance: $\pm 0,5$ mm

Tighten screws with a torque wrench.
Use suitable washers, if necessary.

Strength:	8.8
Tightening torque:	24 N·m

4.3 Basic Assembly

4.3.1 Assembly Example

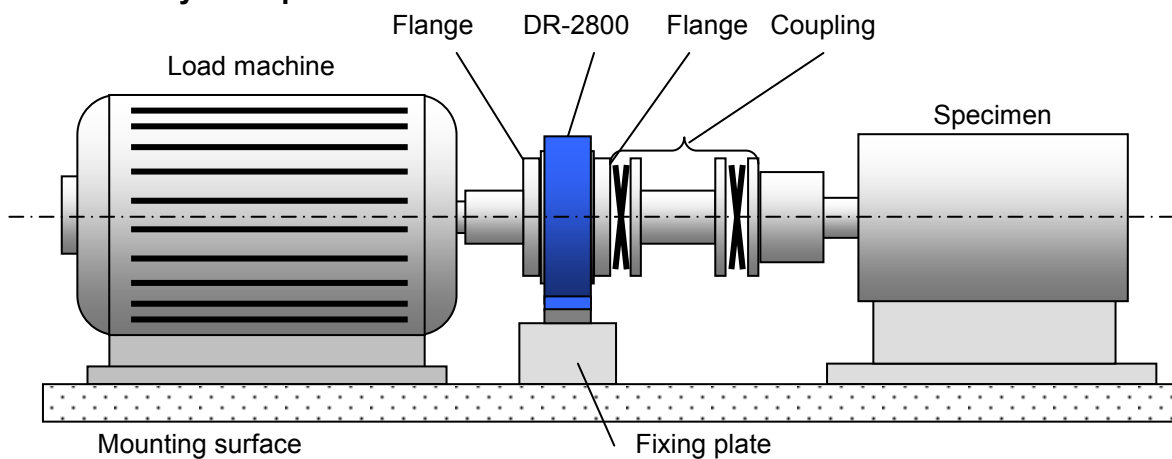

To keep shear forces and axial forces to a minimum, shiftable couplings must be used. See chapter couplings in this manual.

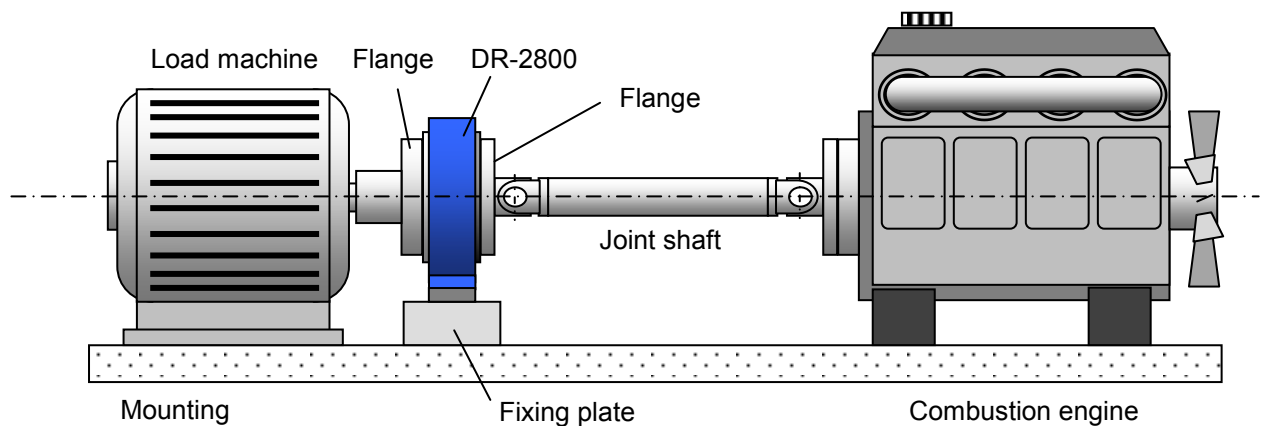

Example combustion engine with joint shaft

Angular displacements result in additional forces on the torque sensor. See data of the manufacturer of the joint shafts.

4.3.2 Using Center Bore

Each part, led through the sensor, means a torque shunt.

- By this, a torque portion will bypass the sensor.
- This portion is not measured → so the shunt must be small in relation to the measured torque.

The large center bore is suitable for the lead-through of

- hydraulic hoses
- pneumatic hoses
- rods

Note:

- The lead-through part may not acquire torque which will influence the measurement result
- Applied torque M_s for twisting of the lead-through parts must be very small against the measured torque M_t .

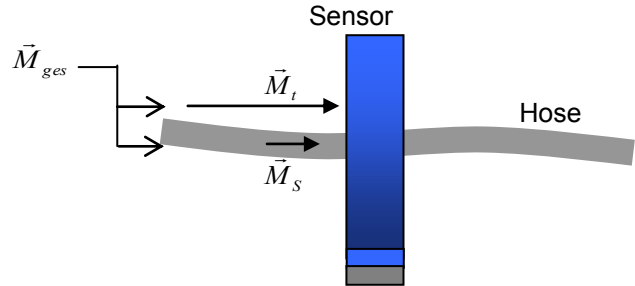

Note at this arrangement:

$$M_{ges} = M_t + M_s$$

$$M_t \gg M_s \implies \text{e.g. } M_s < \frac{1}{2000} M_t$$

Otherwise, a disturbance of the measuring signal will be the result from the torque shunt.

Example for a round shaft:

Twist angle φ of the torque sensor: $\varphi \sim M_t \cdot l / d^4$

Twist angle φ_1 of the lead-through part: $\varphi_1 \sim M_s \cdot l_s / d_s^4$

M = Torque; l = Length of the torsion part; d = Diameter of the torsion part

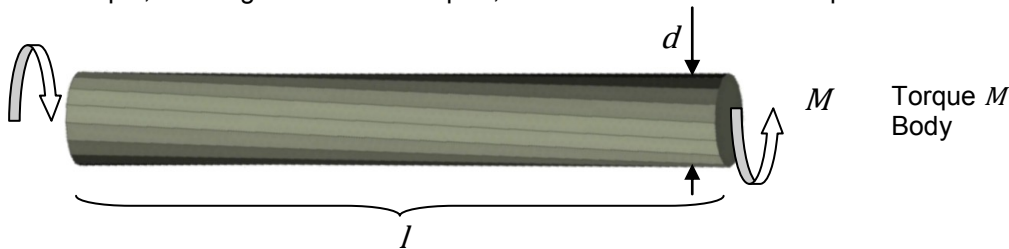

Both twist angles must be the same.

This means: in order to achieve as small as possible torque resulting from the lead-through part it must

- have a small diameter (cross-section)
- be long

4.4 Couplings

Couplings must be able to balance an axial, radial or angular offset of the shafts and not allow large forces to act on the sensor.

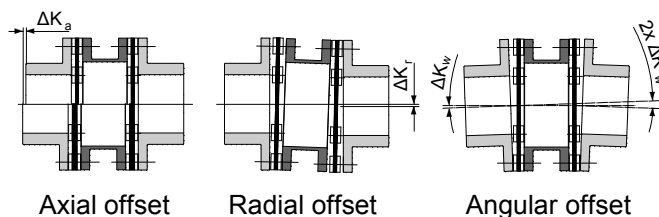



If shear forces and axial forces act on the torque sensors, they can cause zero point shifts, which falsify the measuring signal as a disturbance variable during the measurement.

4.4.1 Alignment of the Measurement Arrangement

Precisely alignment of the couplings reduces the reaction forces and increases the durability of the couplings and the shaft bearing.

Frequently, an alignment of the couplings with a straight edge in two levels, vertical to each other, is sufficient.

At high speed, however, an alignment of the coupling (shaft ends) with a dial indicator or a laser is recommended.

Further points to be considered

- The axis height of the torque sensor (data sheet) must be considered.
- An air gap between rotor and stator must be available. The rotor may not touch the stator in any operating condition.
- Axial position of the rotor to the stator: see data sheet.



For further references see coupling manual and limit thrust load and shear load of the torque sensor (data sheet).

5 Electrical Connection

5.1 Pin Connection

See test certificate, as well.

12-pin	Analog Output	
Pin A	NC	
Pin B	NC	
Pin C	Signal	±5 V / (±10 V)
Pin D	Signal GND	0 V
Pin E	Excitation GND	0 V
Pin F	Excitation +	12 ... 28 VDC
Pin G	Option Speed	TTL
Pin H	NC	
Pin J	NC	
Pin K	NC	
Pin L	NC	
Pin M	Housing	

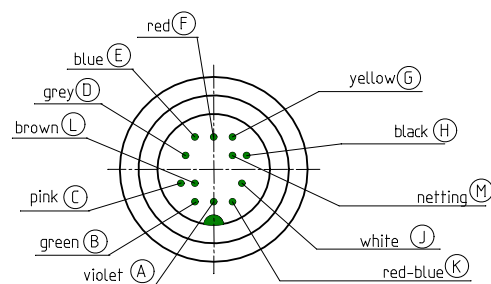

View: socket on soldering side

5.2 Cable

Only use a shielded cable with minimum capacity. We recommend measuring cables from our product range. They have been tested in combination with our sensors and meet the metrological requirements.

5.3 Shielding Connection

In combination with the sensor and the external electronics, the shield forms a Faraday Cage. By this, electro-magnetic disturbances do not have any influence on the measurement signal.

5.4 Installation of Measuring Cables

Do not lay measuring cables together with control lines or power cables. Always assure that a large distance is kept to engines, transformers and contactors, because their stray fields can lead to interferences of the measuring signals.

If troubles occur through the measuring cable, we recommend to lay the cable in a grounded steel conduit.

5.5 Speed Sensor (Option)

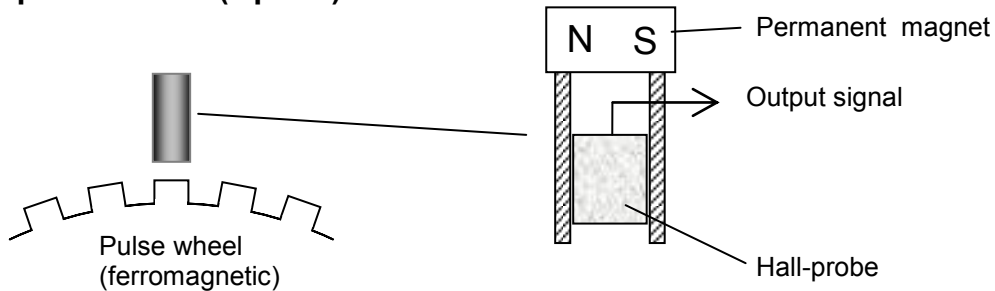

A hall sensor is located between the pulse wheel and the permanent magnet. If a tooth of the pulse wheel passes the energized hall sensor, the field intensity of the permanent magnet changes. By this, hall voltage occurs which is processed to a rectangular signal by the integrated evaluation electronics.

6 Measuring

6.1 Engaging

The warming-up period of the torque sensor is approx. 5 min. Afterwards the measurement can be started.



The warming-up period of the torque sensor is approx. 5 min.

6.2 Direction of Torque

Torque means clockwise torque if the torque acts clockwise when facing the shaft end. In this case a positive electrical signal is obtained at the output.

Torque sensors by Lorenz Messtechnik GmbH can measure both, in clockwise and counter-clockwise direction.

6.3 Static / Quasi-Static Torques

Static and/or quasi-static torque is a slowly changing torque.

The calibration of the sensors occurs statically on a calibration device.

The applied torque can accept any value up to the nominal torque.

6.4 Dynamic Torques

6.4.1 General

The static calibration procedure of torque sensors is also valid for dynamic applications.

Note: The frequency of torques must be smaller than the natural frequency of the mechanical measurement setup.

The band width of alternating torque must be limited to 70 % of the nominal torque.

6.4.2 Torsional Natural Resonances

Estimation of the mechanical natural frequencies:

$$f_0 = \frac{1}{2 \cdot \pi} \cdot \sqrt{c \cdot \left(\frac{1}{J_1} + \frac{1}{J_2} \right)}$$

f_0 = Natural Frequency in Hz
 J_1, J_2 = Moment of Inertia in kg*m²
 c = Torsional Rigidity in Nm/rad

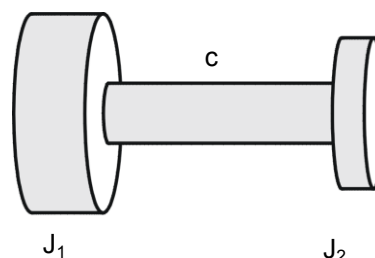

Further methods for the calculation of natural resonances are corresponding purchasable programs or books (e.g. Holzer-Procedure (Dubbel, Taschenbuch für den Maschinenbau, Springer Verlag) or equivalent commercially available programs.



Operation of the device in natural resonance can lead to permanent damages.



6.4.3 Bending Natural Resonances

Together with the shaft and the couplings, the sensor forms a bending vibration.

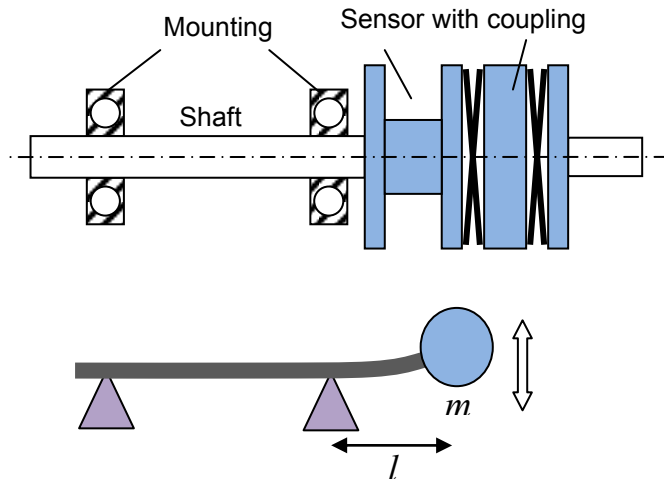

This applies for bending natural resonance:

$$\omega = \sqrt{\frac{3 \cdot \pi \cdot E \cdot d^4}{64 \cdot m \cdot l^3}}$$

E = Elasticity modulus of material
d = Shaft diameter

m = Mass

$\omega = 2 \cdot \pi \cdot f$ = Angular frequency

f = Natural frequency in Hz

- ⇒ Preferably stable design
- ⇒ Diameter (*d*)
- ⇒ Length *l* preferably short

Bending vibrations are stimulated by unbalance. → balance well
Do not operate the system in bending natural resonance.
Apply bursting protection around the shaft string.



Operation of the device in bending natural resonance can lead to permanent damages .

6.5 Speed Limits

The maximum speed indicated in the data sheet may not be exceeded in any operating state.

6.5.1 Balancing

The sensor is balanced (for balancing quality see datasheet). At high speeds, it is recommended to perform one operational balancing.

Balancing bores may not be applied out on the sensor!

6.6 Disturbance Variables

Measured value falsifications can occur by

- Vibrations,
- Temperature gradients,
- Temperature changes,
- Emerging disturbance variables during operation, e.g. imbalance,
- Electrical disturbances,
- Magnetic disturbances,
- EMC (electromagnetic disturbances),

Therefore avoid these disturbance variables by decoupling of vibrations, covers, etc.

7 Maintenance

Maintenance schedule

Action	Frequency	Date	Date	Date
Control of cables and connectors	1x p.a.			
Calibration	< 26 months			
Control of fixation (flanges, shafts)	1x p.a.			

7.1 Rotating Sensors

This sensor type is largely maintenance free.



7.2 Trouble Shooting

This table is used to find the most common errors and debugging.

Problem	Possible Cause	Debugging
No signal	No sensor excitation	<ul style="list-style-type: none"> • Outside of permissible range • Connect excitation • Cable defect • No mains supply
	Signal output connected wrong	<ul style="list-style-type: none"> • Connect output correctly • Evaluation electronics defect
Sensor does not react to torque	Shaft not clamped	<ul style="list-style-type: none"> • Clamp correctly
	No power supply	<ul style="list-style-type: none"> • Outside of permissible range • Connect supply • Cable defect • No mains supply
	Cable defect	<ul style="list-style-type: none"> • Repair cable
	Connector connected wrong	<ul style="list-style-type: none"> • Connect correctly
Signal has dropouts	Axial position rotor to stator outside of tolerance	<ul style="list-style-type: none"> • Align rotor
	Cable defect	<ul style="list-style-type: none"> • Repair cable
Zero point outside of tolerance	Cable defect	<ul style="list-style-type: none"> • Repair cable
	Shaft mounted distorted	<ul style="list-style-type: none"> • Mount correctly
	Distorted shaft string	<ul style="list-style-type: none"> • Release distortion
	Strong lateral forces	<ul style="list-style-type: none"> • Reduce lateral forces
	Distorted flanges	<ul style="list-style-type: none"> • Check evenness of flange-surfaces
	Shaft overloaded	<ul style="list-style-type: none"> • Send to manufacturer
Wrong torque indication	Calibration not correct	<ul style="list-style-type: none"> • Re-calibrate
	Sensor defect	<ul style="list-style-type: none"> • Repair by manufacturer
	Torque shunt	<ul style="list-style-type: none"> • Eliminate shunt
Shaft grinds	Shaft grinds in the rotor	<ul style="list-style-type: none"> • Align shaft • Concentricity of the parts is not ensured
	Lateral forces too large	<ul style="list-style-type: none"> • Decrease lateral forces
Oscillations	Alignment of shaft not correct	<ul style="list-style-type: none"> • Align correctly
	Unbalance	<ul style="list-style-type: none"> • Balance the corresponding parts

8 Decommissioning

All sensors must be dismantled professionally. Couplings may not be damaged. Do not strike sensor housings with tools. Do not exert punches on the sensor with a tool. Do not apply bending moments on the sensor, e.g. through levers. The torque sensor must be supported to avoid falling down during the dismantling.

9 Transportation and Storage

The transportation of the sensors must occur in suitable packing. The sensor should be wrapped in foil, so no packing material can get into the device. Larger sensors should be packed in boxes. Use the supplied fixing plates for storage or transportation of the sensor.

9.1 Transportation

Only release well packed sensors for transportation. The sensor should not be able to reciprocate in the packing. The sensor must be protected from moisture. Use only suitable means of transportation.

9.2 Storage

The storage of the sensors must occur in dry, dust-free rooms, only. Lightly oil shafts and flanges before storing (rust).



10 Disposal

The torque sensors must be disposed in accordance with applicable legislation. For this, see our "General Terms and Conditions" www.lorenz-sensors.com

11 Calibration

At the time of delivery, torque sensors have been adjusted and tested with traceable calibrated measuring equipment at factory side. Optionally, a calibration of the sensors can be carried out.

11.1 Proprietary Calibration

Acquisition of measurement points and issue of a calibration protocol Traceable calibrated measuring equipment is being used for the calibration. The sensor data are being checked during this calibration.

11.2 DKD-Calibration

The calibration of the sensor is carried out according to the guidelines of the DKD and/or DAkkS.. The surveillance of the calibrating-laboratory takes place by the DAkkS. At this calibration, the uncertainty of measurement of the torque measuring instrument is determined. Further information can be obtained from Lorenz Messtechnik GmbH.

11.3 Re-Calibration

The recalibration of the torque sensor should be carried out after 26 months at the latest. Shorter intervals are appropriate:

- Overload of the sensor
- After repair
- After inappropriate handling
- Demand of high-quality standards
- Special traceability requirements

12 Data Sheet

See www.lorenz-sensors.com

13 Literature

Dubbel, Taschenbuch für den Maschinenbau, Springer Verlag.