

The SR1J is a rugged, low-cost, easy to install high performance string pots built for wet environments and outdoor applications.

The SR1J comes in two ranges: 0-125 inches and 0-175 inches and is the perfect low-cost J1939 CANbus solution for mobile applications such as mobile crane outrigger position or hydraulic lifts. Every unit ships with a handy mounting bracket giving the user the ultimate flexibility to easily orient the measuring cable to one of four different directions.

### Ordering Information:

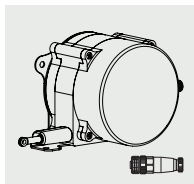

Order No.  
**SR1J-125**  
- 125-inch stroke range  
- CANBus J1939 Communication  
- 5-pin M12 field installable mating plug  
- mounting bracket

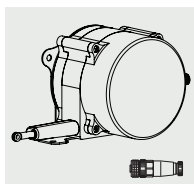

Order No.  
**SR1J-175**  
- 175-inch stroke range  
- CANBus J1939 Communication  
- 5-pin M12 field installable mating plug  
- mounting bracket

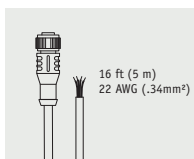

Order No.  
**9036810-0030**  
for short-run connections,  
optional 16-ft (5 m) long cordset  
with 5-pin M12 mating plug.

# SR1J

## Cable Actuated Sensor Industrial • CANBus J1939

Two Available Stroke Ranges: 0-125 in & 0-175 in.

Rugged Polycarbonate Enclosure • Simple Installation

Designed for Outdoor & IP67 environments

**IN STOCK FOR QUICK DELIVERY!**

### Specifications

Full Stroke Range, SR1J-125	125 inches (3175 mm), maximum
Full Stroke Range, SR1J-175	175 inches (4445 mm), maximum
Repeatability	.05% FS.
Resolution	12-bit
Input Voltage	10-36 VDC
Input Current	100 mA, max.
Maximum Velocity	80 inches (2 meters) per second
Maximum Acceleration	10 g (retraction)
Measuring Cable Tension	23 oz. (6.4 N) ±30%
Sensor	plastic-hybrid precision potentiometer
Cycle Life	250,000 (potentiometer)
Enclosure	polycarbonate
Measuring Cable	.031-inch dia. bare stainless rope
Electrical Connection	M12 Connector (mating plug included)
Environmental Suitability	NEMA 6, IP67
Operating Temperature	-40° to 185° F (-40° to 85° C)
Weight	2.5 lbs. (1.3 Kg)

### CANbus Specifications

Communication Profile	CANbus SAE J1939
Protocol	Proprietary B
Node ID	Adjustable via dipswitch (0-63), default set to 0
Baud Rate Options	125K (default), 250K, 500K
Data Rate Options	5ms (default), 20ms, 50ms, 100ms

**Electrical Connection**

output signal	connector pin	colorcode (cordset)
n/c	1	brown
10...36 VDC common	2	white
CAN high	3	blue
CAN low	4	black
	5	green/yellow

**M12 Connector (included)**

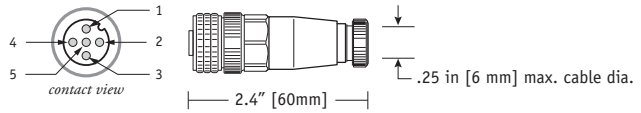

**16 ft. Cordset (optional)**

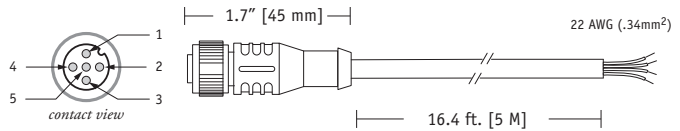

**Internal Controller Board**

**LSS, Baud Rate and Node ID settings:**

LSS, Baud Rate and Node ID settings are set via dip switch found on the internal controller board. To gain access to the controller board, remove the 4 cover attaching screws and carefully separate the sensor cover from the main body.

Follow the instructions on the following pages for desired settings and reinstall sensor cover.

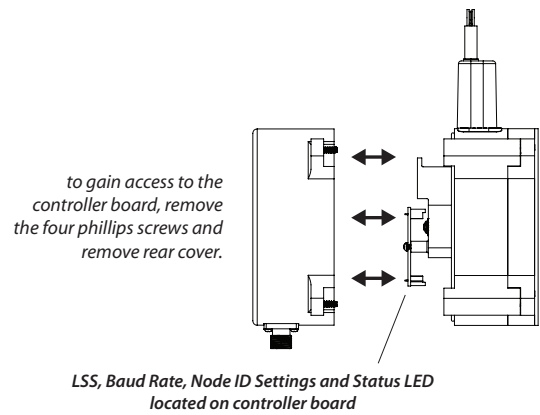

**Baud, Node ID and Data Rate:**

Baud Rate, Node ID and Data Rate settings are set via dip switch found on the internal controller board. To gain access to the controller board, remove the 4 cover attaching screws and carefully separate the sensor cover from the main body. Be careful not to damage the small gage wires that connect the controller board to the connector mounted directly to the rear cover.

node ID Dec. Hex	SW1	SW2	SW3	SW4	SW5	SW6
	(2 <sup>0</sup> )	(2 <sup>1</sup> )	(2 <sup>2</sup> )	(2 <sup>3</sup> )	(2 <sup>4</sup> )	(2 <sup>5</sup> )
0 0x00	off	off	off	off	off	off
1 0x01	on	off	off	off	off	off
2 0x02	off	on	off	off	off	off
3 0x03	on	on	off	off	off	off
...	...	...	...	...	...	...
62 0x3E	off	on	on	on	on	on
63 0x3F	on	on	on	on	on	on

node ID options 0-63 (0x00-0x3F)

BAUD rate options	SW7	SW8
	(2 <sup>6</sup> )	(2 <sup>7</sup> )
125 kbps	off	off
250 kbps	on	off
500 kbps	off	on

Data Rate options	SW9	SW10
	(2 <sup>8</sup> )	(2 <sup>9</sup> )
5 ms	off	off
20 ms	on	off
50 ms	off	on
100 ms	on	on

I/O Format:

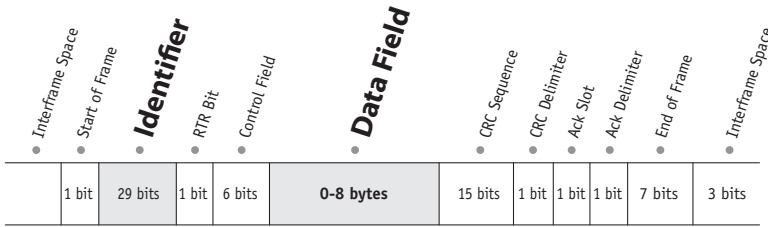

Position Data Overview

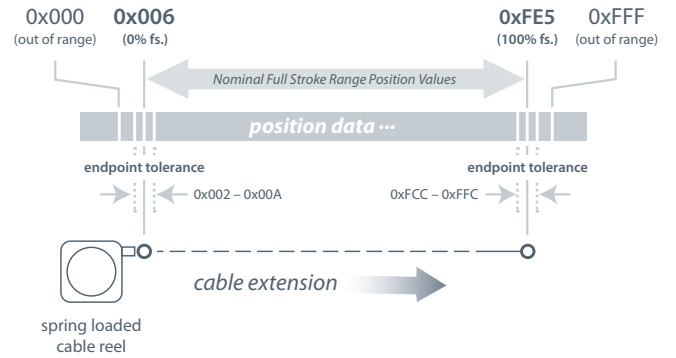

Identifier:

	Message Priority	Future Use	J1939 Reference Proprietary B								Data Field Type*						Not Used		Node ID**											
Example	1	0	0	0	0	1	1	1	1	1	1	1	1	1	0	1	0	1	0	0	1	1	0	0	1	1	1	1	1	1
Identifier Bit No.	28	27	26	25	24	23	22	21	20	19	18	17	16	15	14	13	12	11	10	9	8	7	6	5	4	3	2	1	0	
Hex Value	0				F				F				5			3			3		F									

\*Sensor field data can be factory set to customer specific value. \*\*Customer defined, set via Dips 1-6. Bit values shown for example only, see Address Setting below.

Data Field:

B<sub>0</sub> = LSB current measurement count byte  
 B<sub>1</sub> = MSB current measurement count byte  
 B<sub>2</sub> = not used  
 B<sub>3</sub> = not used

B<sub>4</sub> = error flag  
 B<sub>5</sub> = error flag  
 B<sub>6</sub> = LSB velocity data byte  
 B<sub>7</sub> = MSB velocity data byte

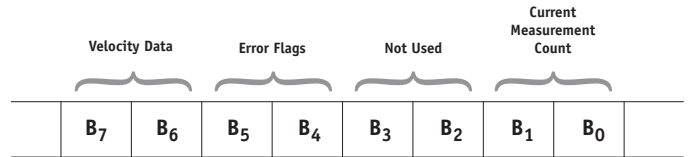

B <sub>7</sub>	B <sub>6</sub>	B <sub>5</sub>	B <sub>4</sub>	B <sub>3</sub>	B <sub>2</sub>	B <sub>1</sub>	B <sub>0</sub>
----------------	----------------	----------------	----------------	----------------	----------------	----------------	----------------

B <sub>7</sub>	B <sub>6</sub>	B <sub>5</sub>	B <sub>4</sub>	B <sub>3</sub>	B <sub>2</sub>	B <sub>1</sub>	B <sub>0</sub>
----------------	----------------	----------------	----------------	----------------	----------------	----------------	----------------

Current Measurement Count

The Current Measurement Count (CMC) is the output data that indicates the present position of the measuring cable. The CMC is a 12-bit value that occupies bytes B<sub>0</sub> and B<sub>1</sub> of the data field. B<sub>0</sub> is the LSB (least significant byte) and B<sub>1</sub> is the MSB (most significant byte).

The CMC starts at 0x006 with the measuring cable fully retracted and continues upward to the end of the stroke range stopping at 0xFE5. This holds true for all ranges.

Error Flags

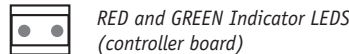

0x00 (GREEN - ON, RED - OFF) indicates the sensor is operating within normal calibrated limits.

0x33, 0x55, 0xAA, 0xCC (RED or GREEN - FLASHING) indicates sensor is at or beyond its calibrated measurement range. Should any of these conditions occur within calibrated range, return unit to factory for evaluation or service.

B <sub>7</sub>	B <sub>6</sub>	B <sub>5</sub>	B <sub>4</sub>	B <sub>3</sub>	B <sub>2</sub>	B <sub>1</sub>	B <sub>0</sub>
----------------	----------------	----------------	----------------	----------------	----------------	----------------	----------------

Velocity

Data in bytes B<sub>7</sub> - B<sub>6</sub> is the change in the CMC (current measurement count) over a 100 msec time period. This data can then be used to calculate velocity in a post processing operation.

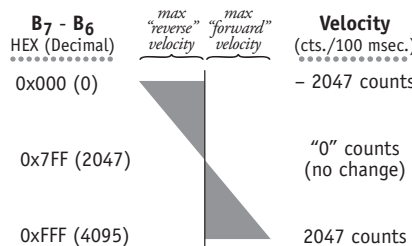

Converting CMC to Linear Measurement

To convert the current measurement count to inches or millimeters, simply divide the count by 4061 (total counts over the range) and then multiply that value by the full stroke range:

$$\left( \frac{\text{CMC} - 6}{4063} \right) \times \text{full stroke range}$$

Sample Conversion:

If the full stroke range is 125 inches and the current position is 0x4FF (1279 Decimal) then,

$$\left( \frac{1279 - 6}{4061} \right) \times 125 = 39.2 \text{ inches}$$

Velocity Calculation

$$\left( \frac{\text{count change} - 2047}{.1 \text{ sec. time period}} \right) \times \left( \frac{\text{full stroke range}}{4063} \right)$$

Sample Calculations

Cable Extension (positive direction):

B<sub>7</sub>..B<sub>6</sub> = 0x8D3 (2259Dec), full stroke = 125 in.

$$\left( \frac{2259 - 2047}{.1 \text{ sec}} \right) \times \left( \frac{125 \text{ in.}}{4063} \right) = 65.22 \text{ in. / sec.}$$

Cable Retraction (negative direction):

B<sub>7</sub>..B<sub>6</sub> = 0x7D0 (2000Dec), full stroke = 125 in.

$$\left( \frac{2000 - 2047}{.1 \text{ sec}} \right) \times \left( \frac{125 \text{ in.}}{4063} \right) = -14.46 \text{ in. / sec.}$$

### Changing the Cable Exit

#### Changing Measuring Cable Exit

To change the direction of the measuring cable, remove the 4 mounting bracket screws and rotate bracket to one of four available positions. See figures 1 - 4 on the following pages for mounting dimensions.

#### Changing Electrical Connector Direction

To change the position of the electrical connector, remove the 4 rear cover screws and carefully separate rear cover from the sensor body.

Rotate the rear cover to desired position being careful not to tangle the wiring harness that runs to the connector.

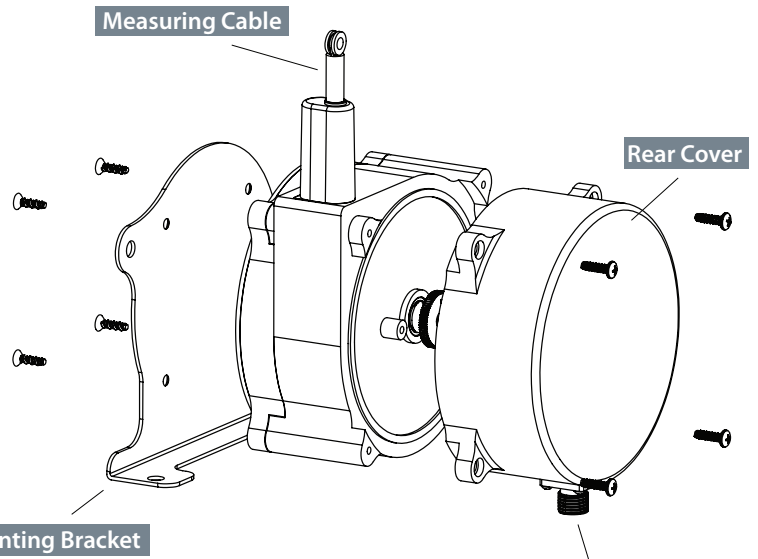

### Cable Exit Direction Options

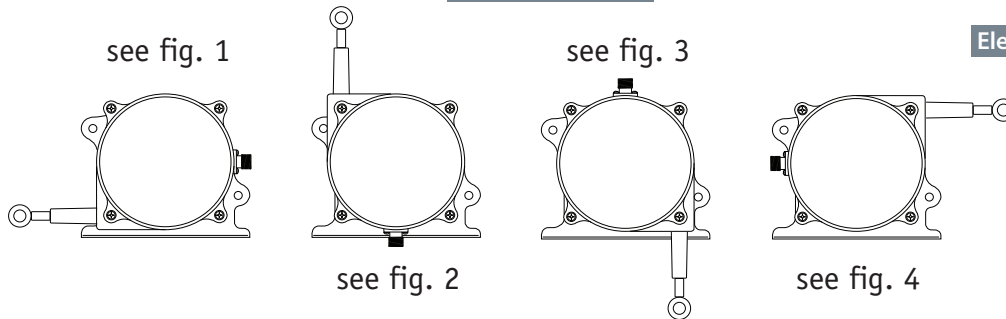
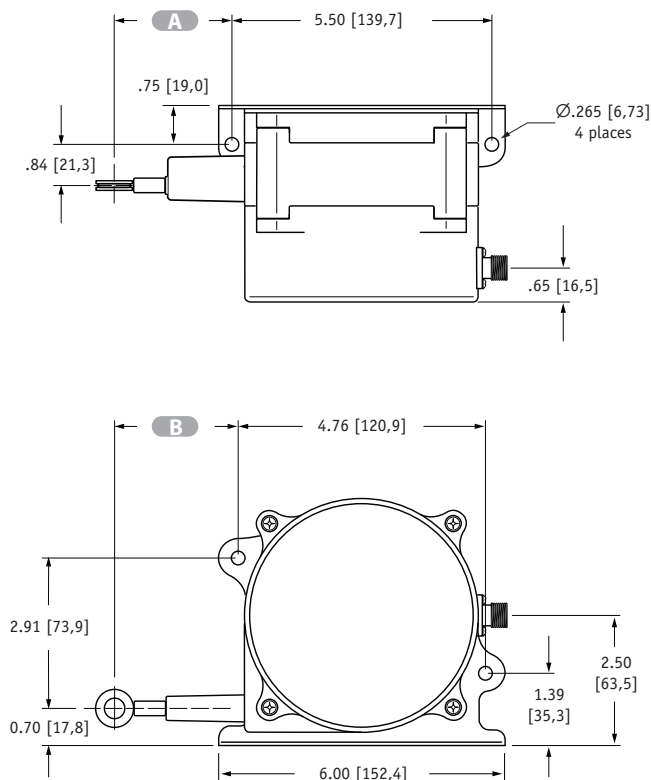
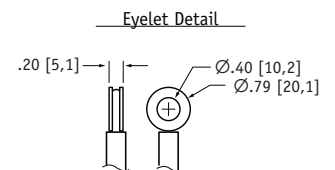
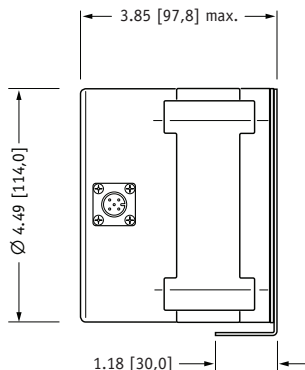
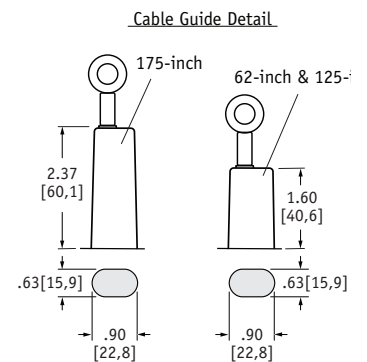

Fig. 1 - Outline Drawing (as shipped)



Model	A	B
125-inch	2.00 ±.13 [50,8 ±3,3]	2.37 ±.13 [60,22 ±3,3]
175-inch	2.87 ±.13 [72,8 ±3,2]	3.24 ±.13 [82,2 ±3,2]



units are in inches [mm] tolerances are ± .04 [1,0] unless otherwise noted

Fig. 2 - "Up" Cable Exit Direction

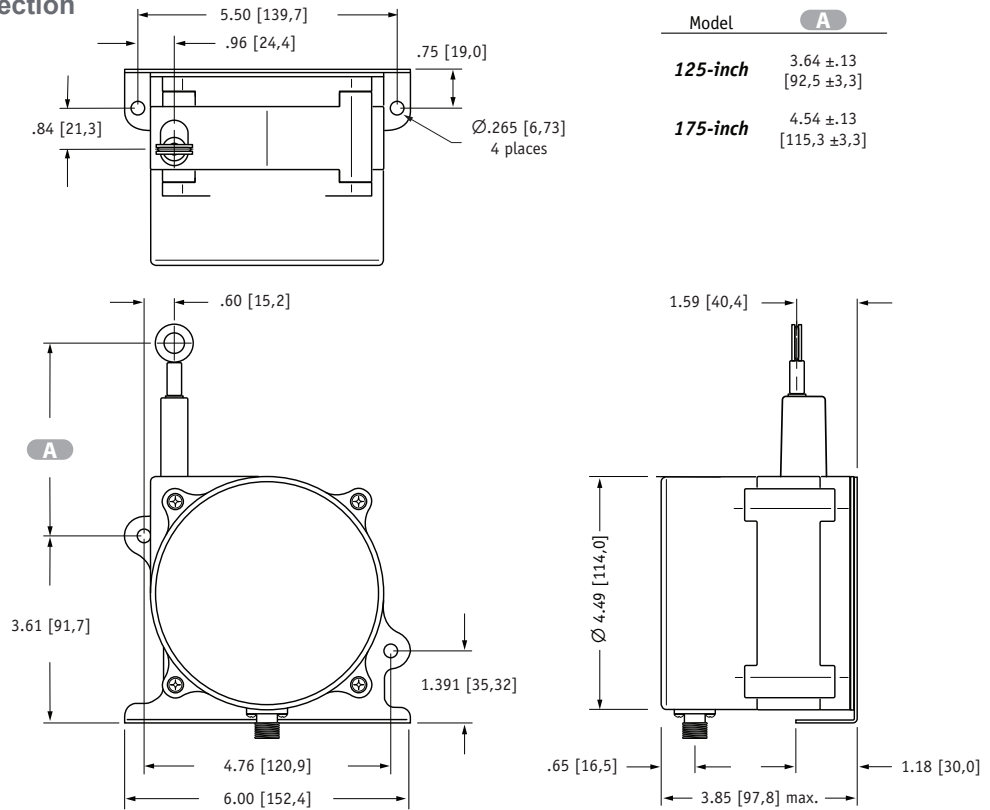

Fig. 3 - "Down" Cable Exit Direction

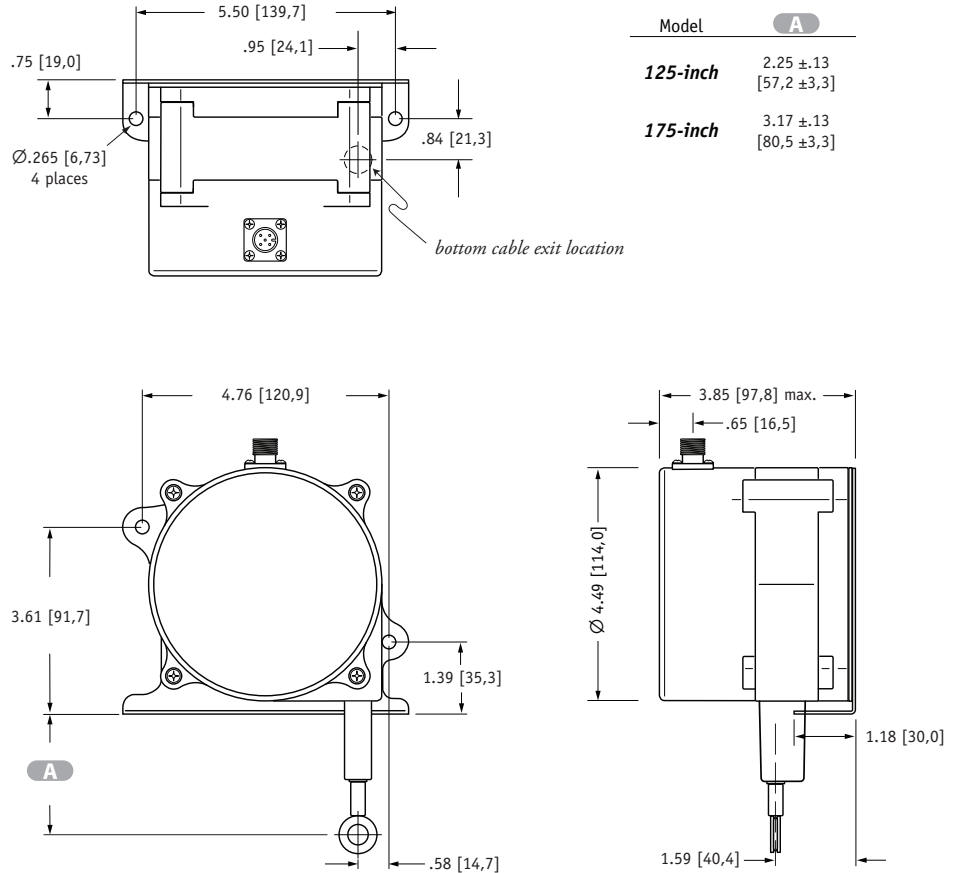
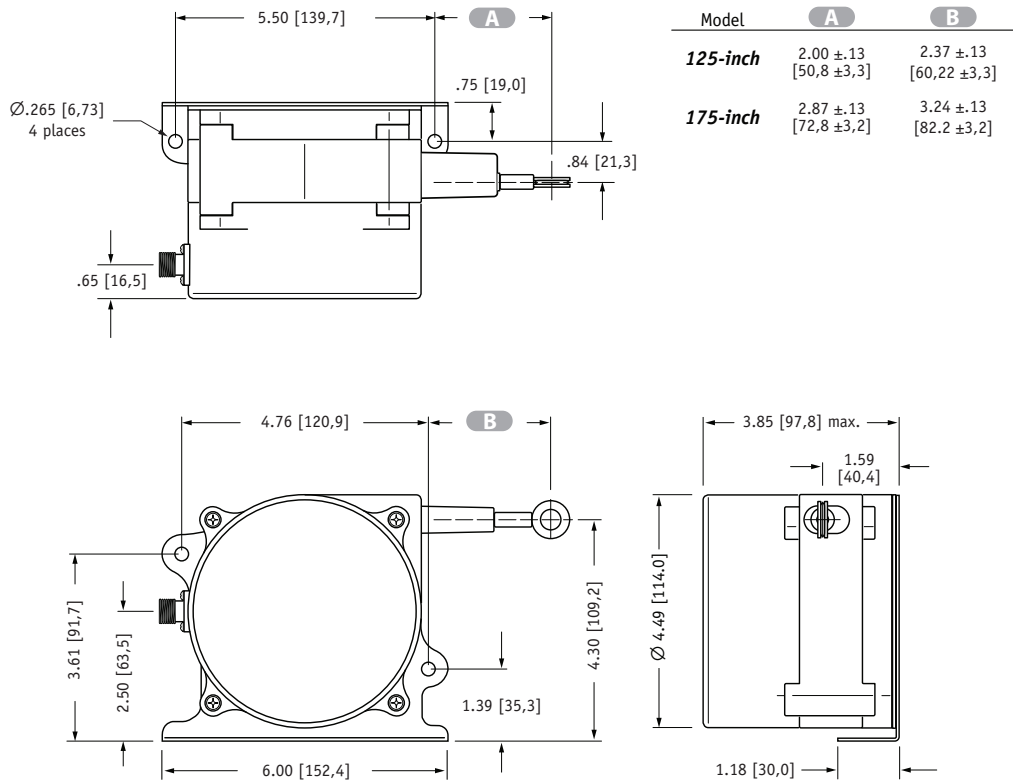

Fig. 4 - "Rear" Cable Exit Direction



units are in inches [mm] tolerances are ± .04 [1,0] unless otherwise noted

**NORTH AMERICA**  
Measurement Specialties, Inc.  
a TE Connectivity Company

20630 Plummer Street  
Chatsworth, CA 91311  
Tel +1-800-423-5483  
Tel +1-818-701-2750  
Fax +1-800-701-2799

customer@te.com

[te.com/sensorsolutions](http://te.com/sensorsolutions)

Measurement Specialties Inc. a TE Connectivity company

Measurement Specialties, TE Connectivity, TE Connectivity (logo) and Every Connection Counts are trademarks. All other logos, products and/or company names referred to herein might be trademarks of their respective owners.

The information given herein, including drawings, illustrations and schematics which are intended for illustration purposes only, is believed to be reliable. However, TE Connectivity makes no warranties as to its accuracy or completeness and disclaims any liability in connection with its use. TE Connectivity's obligations shall only be as set forth in TE Connectivity's Standard Terms and Conditions of Sale for this product and in no case will TE Connectivity be liable for any incidental, indirect or consequential damages arising out of the sale, resale, use or misuse of the product. Users of TE Connectivity products should make their own evaluation to determine the suitability of each such product for the specific application.

© 2016 TE Connectivity Ltd. family of companies All Rights Reserved.